



Doc. version	0.2
Effective date	2004.04.13
Total pages	21
(Not include this cover page)	

Product Specification

3.5" COLOR TF -LCD MODULE

MODEL NAME: A035CN02 V1

- () Preliminary Specification
- () Final Specification

Note: The content of this specification is subject to change without prior notice.

© 2003 AU Optronics
All Rights Reserved,

DO NOT COPY



Contents:

A. Physical specifications **P3**

B. Electrical specifications **P4**

 1. Pin assignment **P4**

 2. Absolute maximum ratings **P5**

 3. Electrical characteristics **P6**

 a. Typical operating conditions **P6**

 b. Current consumption **P6**

 4. AC Timing **P7**

 a. Timing conditions **P7**

 b. Timing diagram **P7**

C. Optical specifications **P8**

D. Reliability test items **P10**

E. Packing form **P11**

Appendix:

Fig.1 Outline dimension of TFT-LCD module **P12**

Fig.2 Sampling clock timing **P13**

Fig.3 Horizontal display timing range **P14**

Fig.4-(a) Horizontal timing **P15**

Fig.4-(b) Detail horizontal timing **P16**



Fig.5 Vertical shift clock timing. **P17**
Fig.6-(a) Vertical timing (From up to down).. **P18**
Fig.6-(b) Vertical timing (From down to up) **P19**

A. Physical specifications

NO.	Item	Specification	Remark
1	Display resolution (dot)	480(W)×234(H)	
2	Active area (mm)	72(W)×50.544(H)	
3	Screen size (inch)	3.5(Diagonal)	
4	Dot pitch (mm)	0.150(W)×0.216(H)	
5	Color configuration	R. G. B. delta	
6	Overall dimension (mm)	83(W)×60.5(H)×3.2(D)	Note 1
7	Weight (g)	35±5	

Note 1: Refer to Fig. 1.

B. Electrical specifications

1.Pin assignment

Pin No.	Symbol	I/O	Description	Remark
01	GND		Ground for logic circuit	
02	VCC		Supply voltage of logic control circuit for scan driver	
03	VGL	I	Negative power for scan driver	
04	VGH	I	Positive power for scan driver	
05	STVR	I/O	Vertical start pulse	
06	STVL	I/O	Vertical start pulse	
07	CKV	I	Shift clock input for scan driver	
08	U/D	I	Up/Down scan control input	
09	OEV	I	Output enable input for scan driver	
10	VCOM	I	Common electrode driving signal	
11	VCOM	I	Common electrode driving signal	
12	GLED1		LED module 1 Cathode	
13	VLED1		LED module 1 Anode	
14	VLED2		LED module 2 Anode	
15	GLED2		LED module 2 Cathode	
16	L/R	I	Left/Right scan control input	
17	Q1H	I	Analog signal rotate input	
18	OEH	I	Output enable input for data driver	
19	STHL	I/O	Start pulse for horizontal scan line	
20	STHR	I/O	Start pulse for horizontal scan line	
21	CPH3	I	Sampling and shifting clock pulse for data driver	
22	CPH2	I	Sampling and shifting clock pulse for data driver	
23	CPH1	I	Sampling and shifting clock pulse for data driver	
24	DVDD		Supply voltage of logic control for data driver	
25	DVSS		Ground for logic circuit	
26	VA	I	Alternated video signal input (Red)	
27	VB	I	Alternated video signal input (Green)	
28	VC	I	Alternated video signal input (Blue)	
29	AVDD		Supply voltage for analog circuit	
30	AVSS		Ground for analog circuit	

Note 1 : Selection of scanning mode

Setting of scan control input		IN/OUT state For start pulse				Scanning direction
U/D	L/R	STVR	STVL	STHR	STHL	
GND	V _{CC}	OUT	IN	OUT	IN	From up to down, and from left to right.
V _{CC}	GND	IN	OUT	IN	OUT	From down to up, and from right to left.
GND	GND	OUT	IN	IN	OUT	From up to down, and from right to left.
V _{CC}	V _{CC}	IN	OUT	OUT	IN	From down to up, and from left to right.

IN: Input; OUT: Output.

Note 2 : Definition of scanning direction. Refer to figure as below:

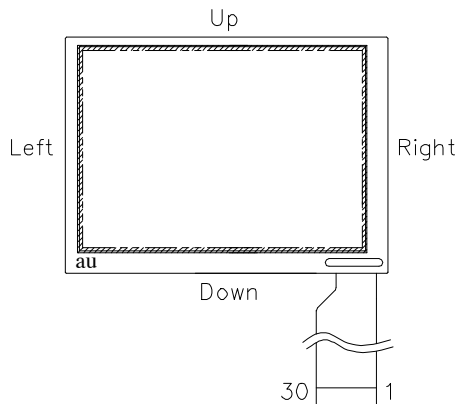

2. Absolute maximum ratings

Item		Condition	Min.	Max.	Unit	Remark
Power voltage	V _{CC}	GND=0	-0.3	7	V	
	AV _{DD}	AV _{SS} =0	-0.3	7	V	
	V _{GH}	GND=0	-0.3	18	V	
	V _{GL}		-18	0.3	V	
	V _{GH} -V _{GL}		-	33	V	
Input signal voltage	V _i		-0.3	AV _{DD} +0.3	V	Note 1
	V _i		-0.3	V _{CC} +0.3	V	Note 2
	V _{COM}		-2.9	5.2	V	
Operating temperature	Topa		0	60	°C	Ambient temperature
Storage temperature	Tstg		-25	80	°C	Ambient temperature

Note 1: VR, VG, VB

Note 2: STHL, STHR, Q1H, OEH, L/R, CPH1~CPH3, STVR, STVL, OEV, CKV, U/D.

3. Electrical characteristics

a. Typical operating conditions (GND=AVss=0V, Note 5)

Item	Symbol	Min.	Typ.	Max.	Unit	Remark
Power supply	V_{CC}	3	5	5.2	V	
	AV_{DD}	4.8	5	5.2	V	
	V_{GH}	14.3	15	15.7	V	
	V_{GLAC}	3.5	5	7.5	Vp-p	AC component of V_{GL} . Note 1
	V_{GL-H}	-10	-9.5	-9	V	High level of V_{GL} .
Video signal Amplitude (VR, VG, VB)	V_{iA}	$AV_{SS}+0.4$	-	$AV_{DD}-0.4$	V	Note 2
	V_{iAC}	-	3	-	V	AC component
	V_{iDC}	-	$AV_{DD}/2$	-	V	DC component
VCOM	V_{CAC}	3.5	5	7.5		AC component, Note 3
	V_{CDC}	-	1.1	-	V	DC component
Input Signal voltage	H Level	V_{IH}	$0.8V_{CC}$	-	V_{CC}	Note 4
	L Level	V_{IL}	0	-	$0.2V_{CC}$	

Note 1: The same phase and amplitude with common electrode driving signal (VCOM).

Note 2: Refer to Fig.4- (a)

Note 3: The brightness of LCD panel could be adjusted by the adjustment of the AC component of VCOM.

Note 4: STHL, STHR, Q1 L/R, CPH1~CPH3, STVR, STVL, OEV, CKV, U/D.

Note 5: Be sure to apply V_{CC} , V_{GL} to the LCD first, and then apply V_{GH} .

b. Current consumption (AVss=0V)

Parameter	Symbol	Condition	Min.	Typ.	Max.	Unit	Remark
Current for driver	I_{GH}	$V_{GH}=15V$	-	50	100	μA	
	I_{GL}	$V_{GL-H}=-9.5V$	-	-0.2	-0.6	mA	
	I_{CC}	$V_{CC}=5V$	-	1.5	4	mA	
	I_{DD}	$AV_{DD}=5V$	-	5	10	mA	

c. LED driving conditions

Parameter	Symbol	Min.	Typ.	Max.	Unit	Remark
LED current			20		mA	
LED voltage	V_L		20		V	1
LED Life Time	L_L	(10000)			Hr	Note 1,2

Note 1 : $T_a = 25^\circ C$, $I_L = 20mA$

The voltage (V_L) is dependent on customer design for serial or parallel consideration of 6 LEDs.

Note 2 : Brightness to be decreased to 50% of the initial value.

ALL RIGHTS STRICTLY RESERVED. ANY PORTION OF THIS PAPER SHALL NOT BE REPRODUCED, COPIED, OR TRANSFORMED TO ANY OTHER FORMS WITHOUT PERMISSION FROM AU OPTRONICS CORP.

4. AC Timing

a. Timing conditions

Parameter	Symbol	Min.	Typ.	Max.	Unit.	Remark
Rising time	t_r	-	-	10	ns	Note 1
Falling time	t_f	-	-	10	ns	Note 1
High and low level pulse width	t_{CPH}	299	308	319	ns	CPH1~CPH3
CPH pulse duty	t_{CWH}	40	50	60	%	CPH1~CPH3
CPH pulse delay	t_{C12} t_{C23} t_{C31}	70	$t_{CPH}/3$	$t_{CPH}/2$	ns	CPH1~CPH3
STH setup time	t_{SUH}	35	-	-	ns	STHR,STHL
STH hold time	t_{HDH}	35	-	-	ns	STHR,STHL
STH pulse width	t_{STH}	-	1	-	t_{CPH}	STHR,STHL
STH period	t_H	61.5	63.5		μs	STHR,STHL
OEH pulse width	t_{OEH}	-	3	-	t_{CPH}	OEH
Sample and hold disable time	t_{DIS1}	4	8.6	-	μs	
OEV pulse width	t_{OEV}	-	12	-	t_{CPH}	OEV
CKV pulse width	t_{CKV}	16	28	40	t_{CPH}	CKV
Clean enable time	t_{DIS2}	-	10	-	t_{CPH}	
Horizontal display start	t_{SH}	-	0	-	$t_{CPH}/3$	
Horizontal display timing range	t_{DH}	-	480	-	$t_{CPH}/3$	
STV setup time	t_s	400	-	-	ns	STVL,STVR
STV hold time	t_{HDV}	400	-	-	ns	STVL,STVR
STV pulse width	t_{STV}	-	-	1	t_H	STVL,STVR
Horizontal lines per field	v	256	262	268	t_H	
Vertical display start	sv	-	3	-	t_H	
Vertical display timing range	t_{DV}	-	234	-	t_H	
VCOM rising time	t_{rCOM}	-	-	3	μs	
VCOM falling time	t_{fCOM}	-	-	3	μs	
VCOM delay time	t_{DCOM}	-	-	3	μs	
RGB delay time	t_{DRGB}	-	-	1	μs	

Note 1: For all of the logic signals.

b. Timing diagram

Please refer to the attached drawings, from Fig.2 to Fig.6.

C. Optical specification (Note 1, Note 2, Note 3)

Item	Symbol	Condition	Min.	Typ.	Max.	Unit	Remark
Response time	Rise	$\theta = 0^\circ$	-	20	30	ms	Note 4, 6
	Fall		Tf	-	30	40	
Contrast ratio	CR	At optimized viewing angle	100	150	-		Note 5, 6
Viewing angle	Top	$CR \geq 10$	10	-	-		Note 6, 7
	Bottom		30	-	-		
	Left		40	45	-		
	Right		40	45	-		
Brightness	Y_L	$\theta = 0^\circ$	200	240	-	nit	Note 8
White chromaticity shift	X	$\theta = 0^\circ$	0.25	0.3	0.35		
	y		0.3		0.4		

Note 1: Ambient temperature =25°C.

Note 2: To be measured in the dark room.

Note 3: To be measured at the center area of panel with a viewing cone of 1° by Topcon luminance meter BM-7, after 10 minutes operation.

Note 4: Definition of response time:

The output signals of photodetector are measured when the input signals are changed from "black" to "white" (falling edge) and from "white" to "black" (rising time), respectively.

The response time is defined as the time interval between the 10% and 90% of amplitudes. Refer to figure as below.

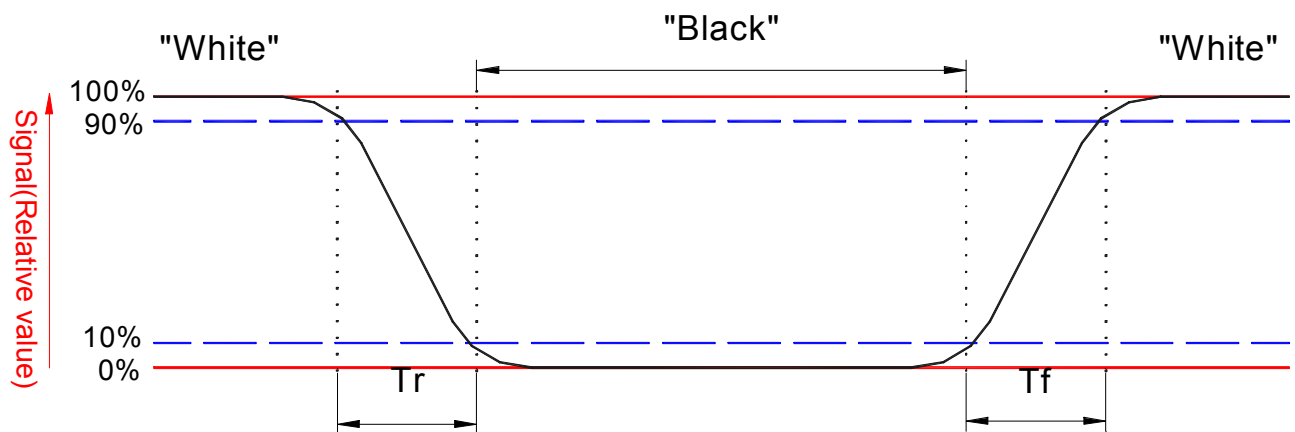

Note 5. Definition of contrast ratio:

Contrast ratio is calculated with the following formula.

$$\text{Contrast ratio (CR)} = \frac{\text{Photodetector output when LCD is at "White" state}}{\text{Photodetector output when LCD is at "Black" state}}$$

Note 6. White $V_i = V_{i50} \mp 1.5V$

Black $V_i = V_{i50} \pm 2.0V$

“±” means that the analog input signal swings in phase with COM signal.

“∓” means that the analog input signal swings out of phase with COM signal.

V_{i50} : The analog input voltage when transmission is 50%

The 100% transmission is defined as the transmission of LCD panel when all the input terminals of module are electrically opened.

Note 7. Definition of viewing angle: Refer to figure as below.

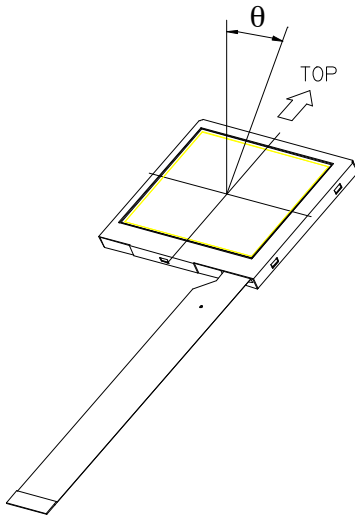

Note 8. Measured at the center area of the panel when all the input terminals of LCD panel are electrically opened.

D. Reliability test items:

No.	Test items	Conditions	Remark
1	High temperature storage	Ta= 80°C 240Hrs	
2	Low temperature storage	Ta= -25°C 240Hrs	
3	High temperature operation	Ta= 60°C 240Hrs	
4	Low temperature operation	Ta= 0°C 240Hrs	
5	High temperature and high humidity	Ta= 60°C . 90% RH 240Hrs	Operation
6	Heat shock	-25°C~80°C , 50 cycles, 2H/cycle	Non-operation
7	Electrostatic discharge	±200V,200pF(0Ω), once for each terminal	Non-operation
8	Vibration	Frequency range : 10~55Hz Stoke mm Sweep : 10~55Hz~10Hz 2 hours for each direction of X,Y,Z (6 hours for total)	JIS C7021, A-10 condition A
9	Mechanical shock	100G 6ms, ± ±Y,±Z 3 times for irection	JIS C7021, A-7 condition C
10	Vibration (with carton)	Random vibration: 0.015G ² /Hz from 5~200Hz -6dB/Octave from 200~500Hz	IEC 68-34
11	Drop (with carton)	Height: 80cm 1 corner, 3 edges, 6 surfaces	

Note: Ta: Ambient temperature.

E. Packing form

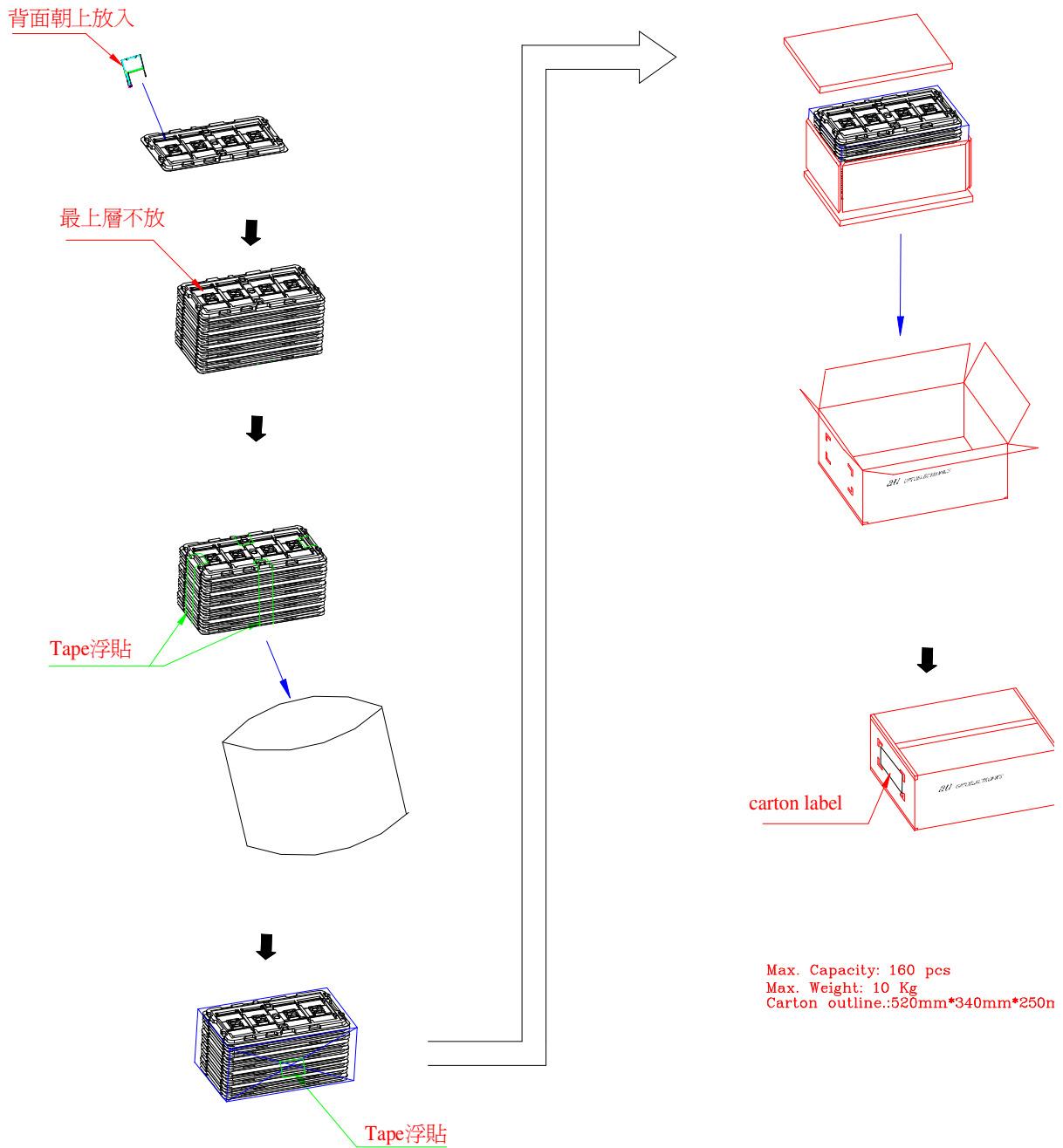

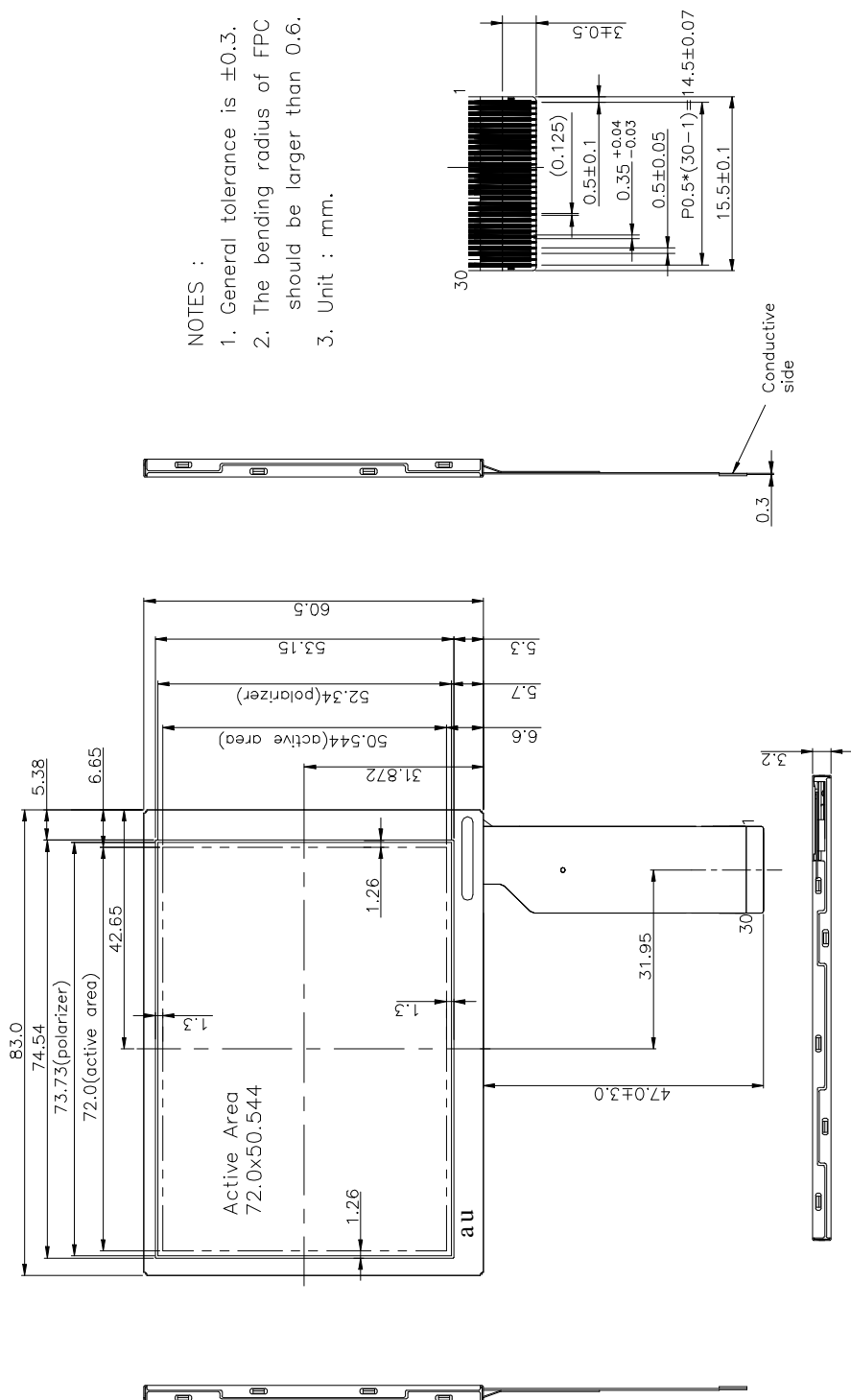

- NOTES :
1. General tolerance is ±0.3.
 2. The bending radius of FPC should be larger than 0.6.
 3. Unit : mm.

Fig.1 Outline dimension of TFT-LCD module

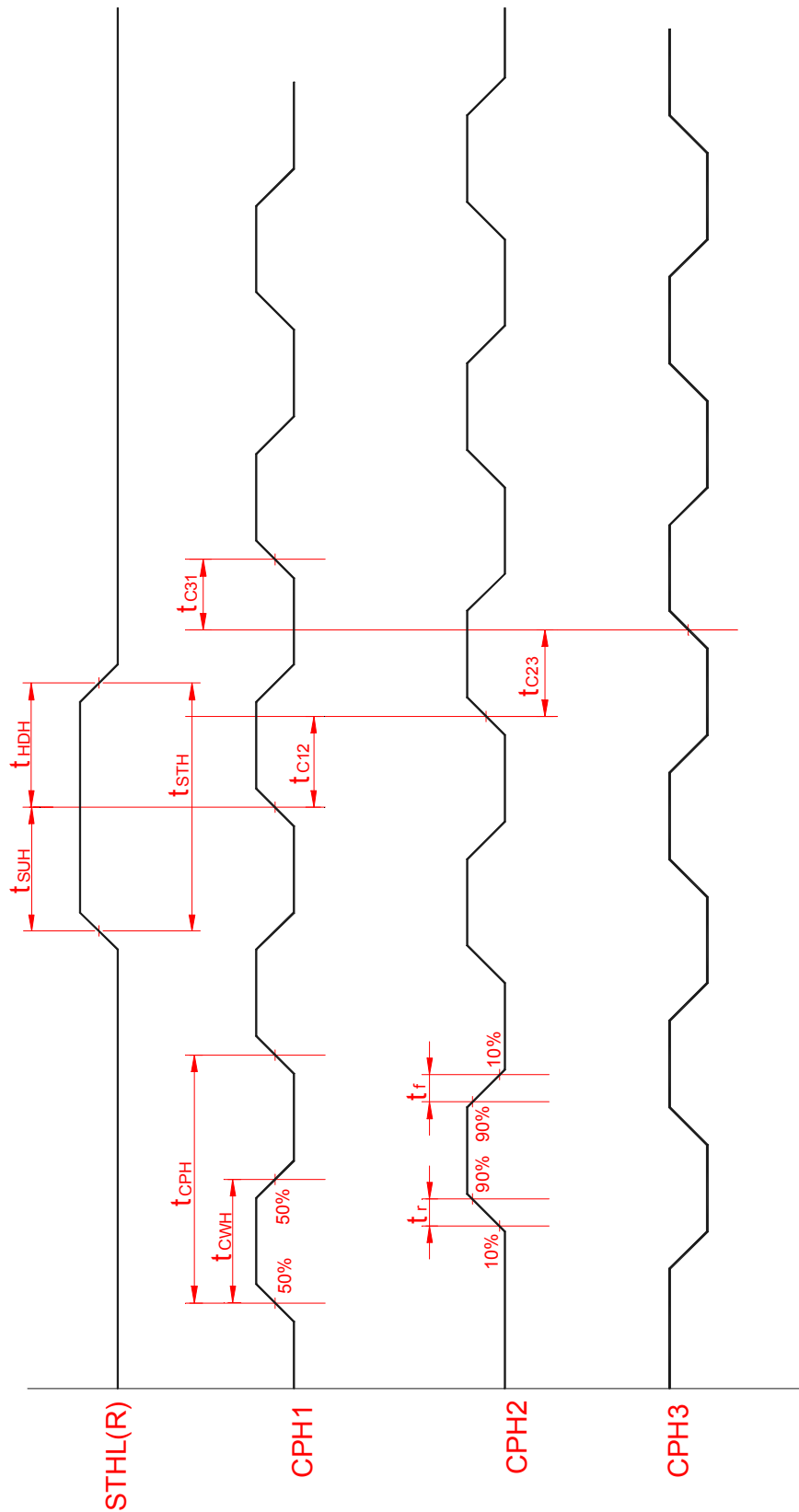

Fig.2 Sampling clock timing

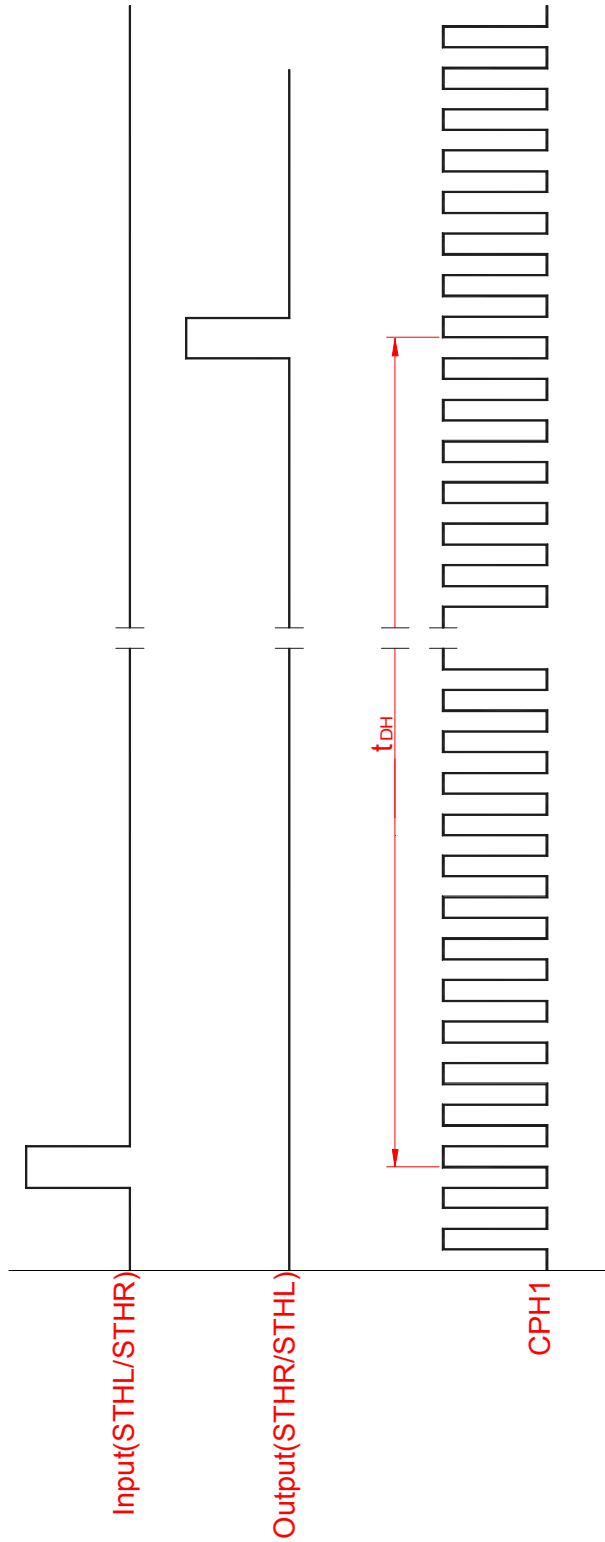

Fig.3 Horizontal display timing range

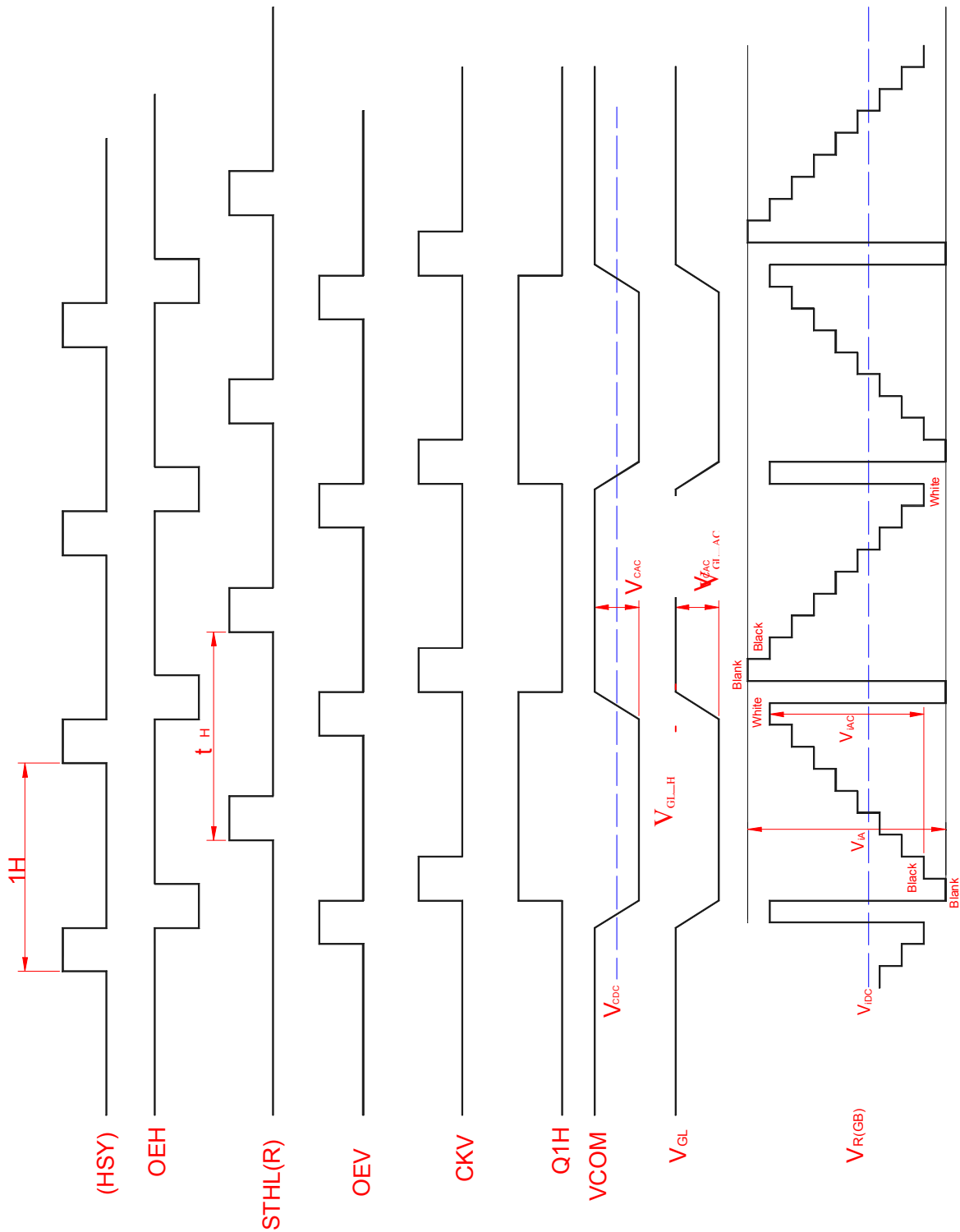

Fig.4(a) Horizontal timing

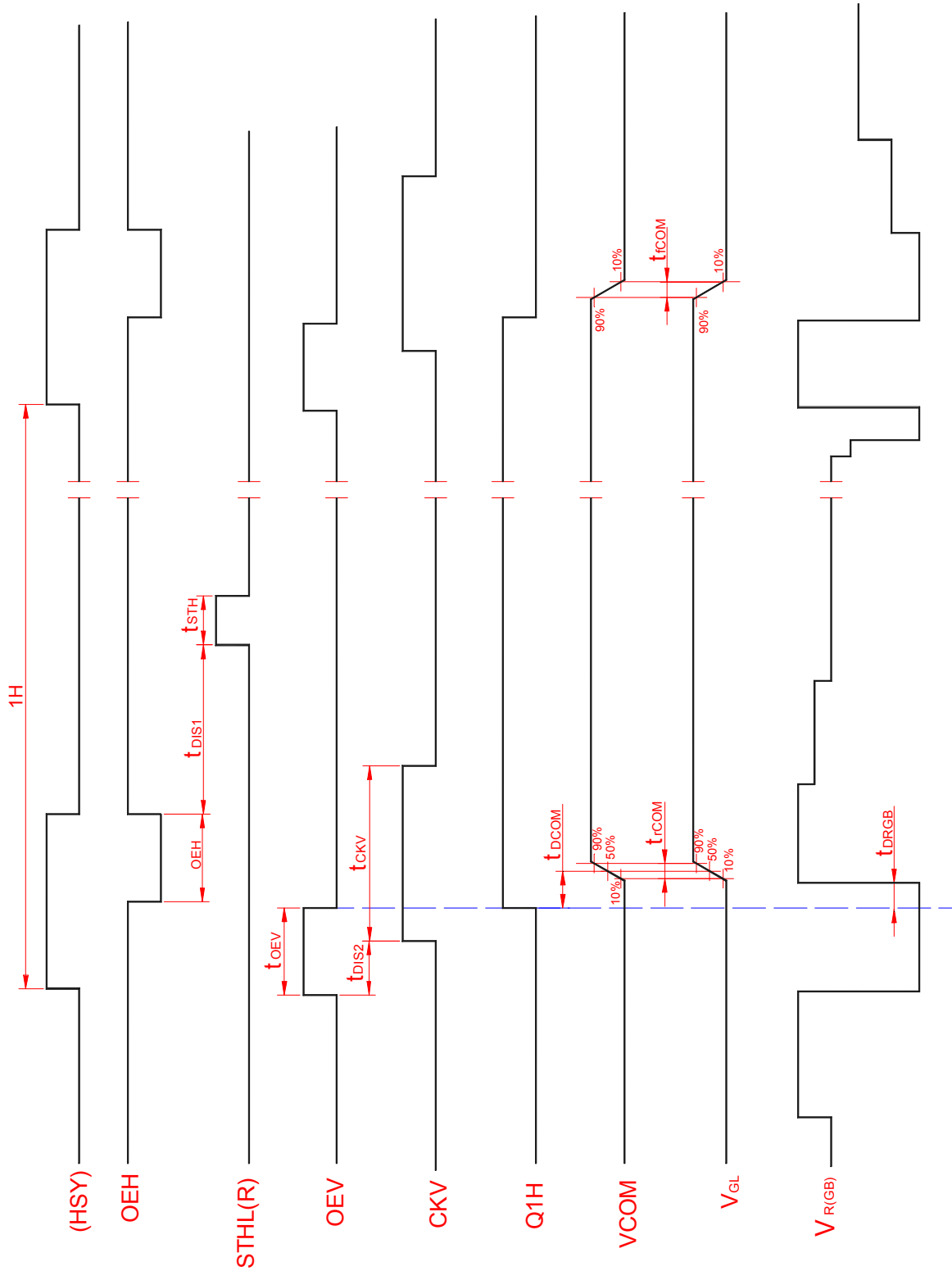

Fig.4-(b) Detail horizontal timing

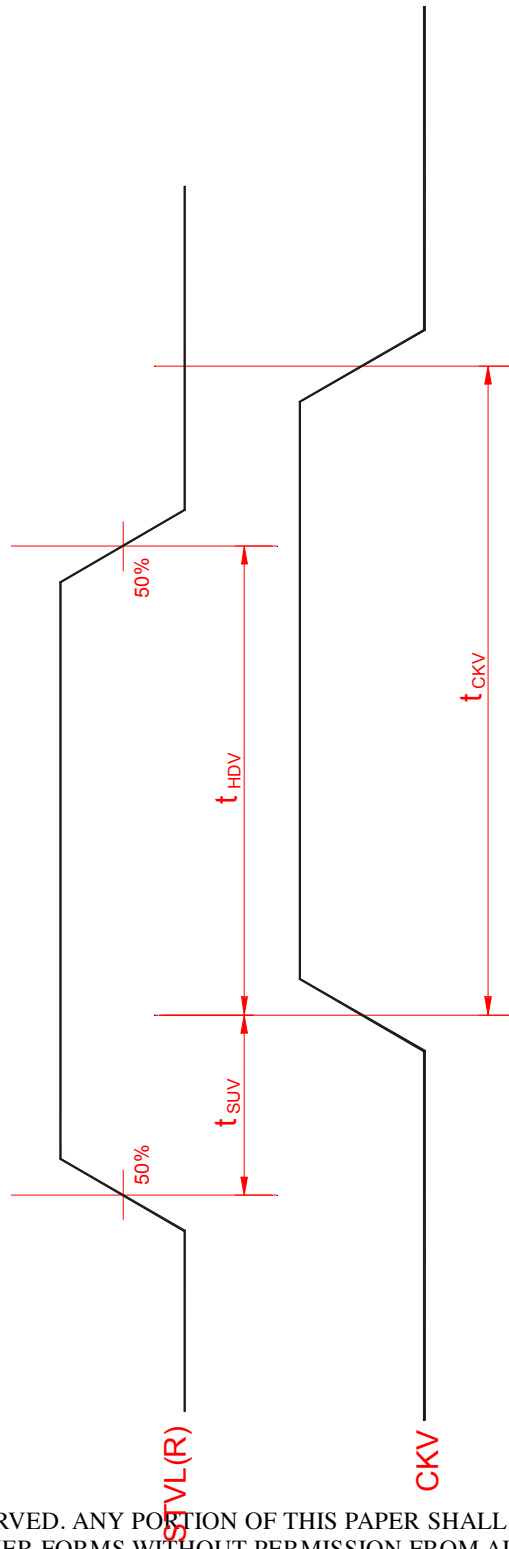

Fig.5 Vertical shift clock timing

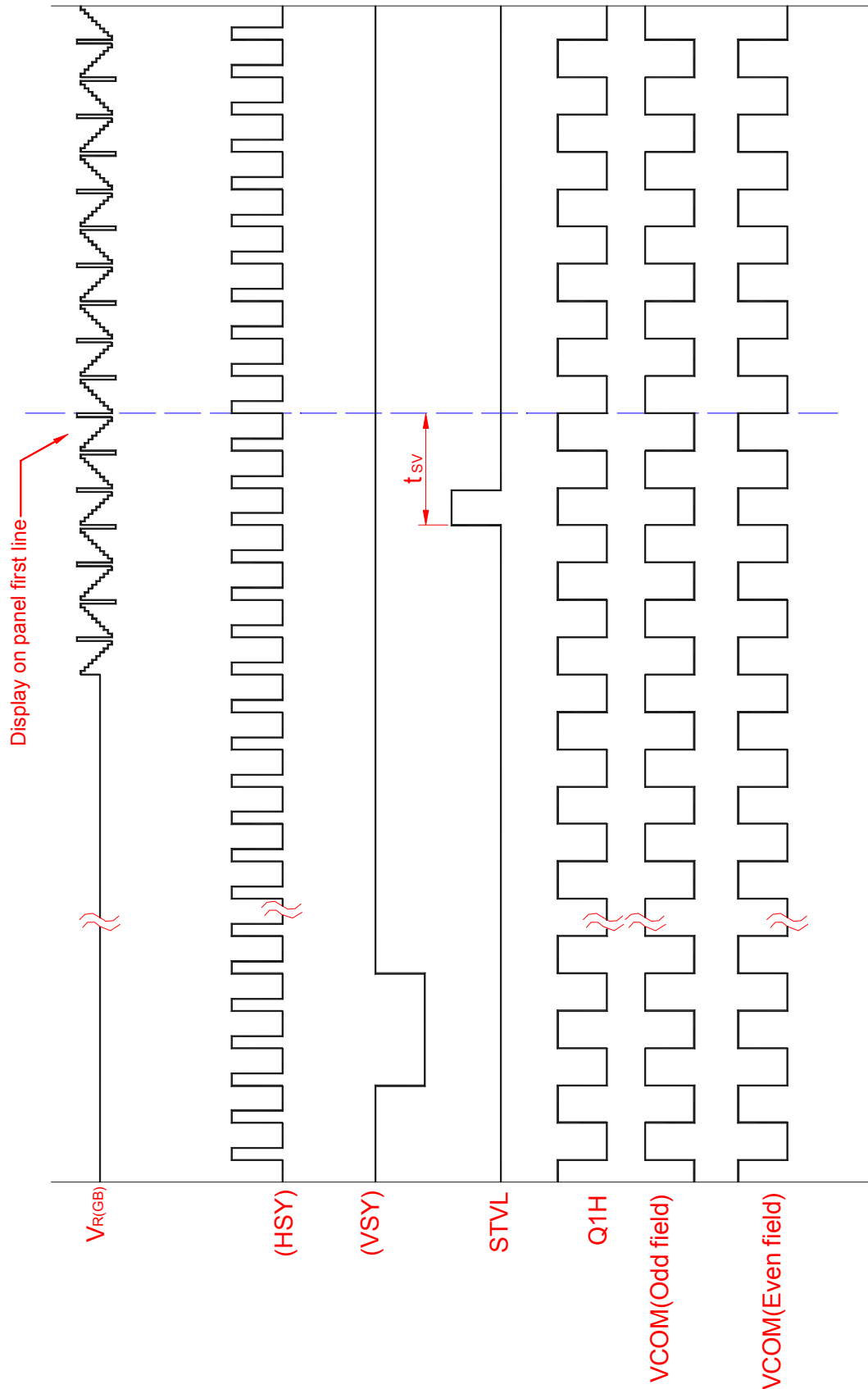

Fig.6-(a) Vertical timing (From up to down)

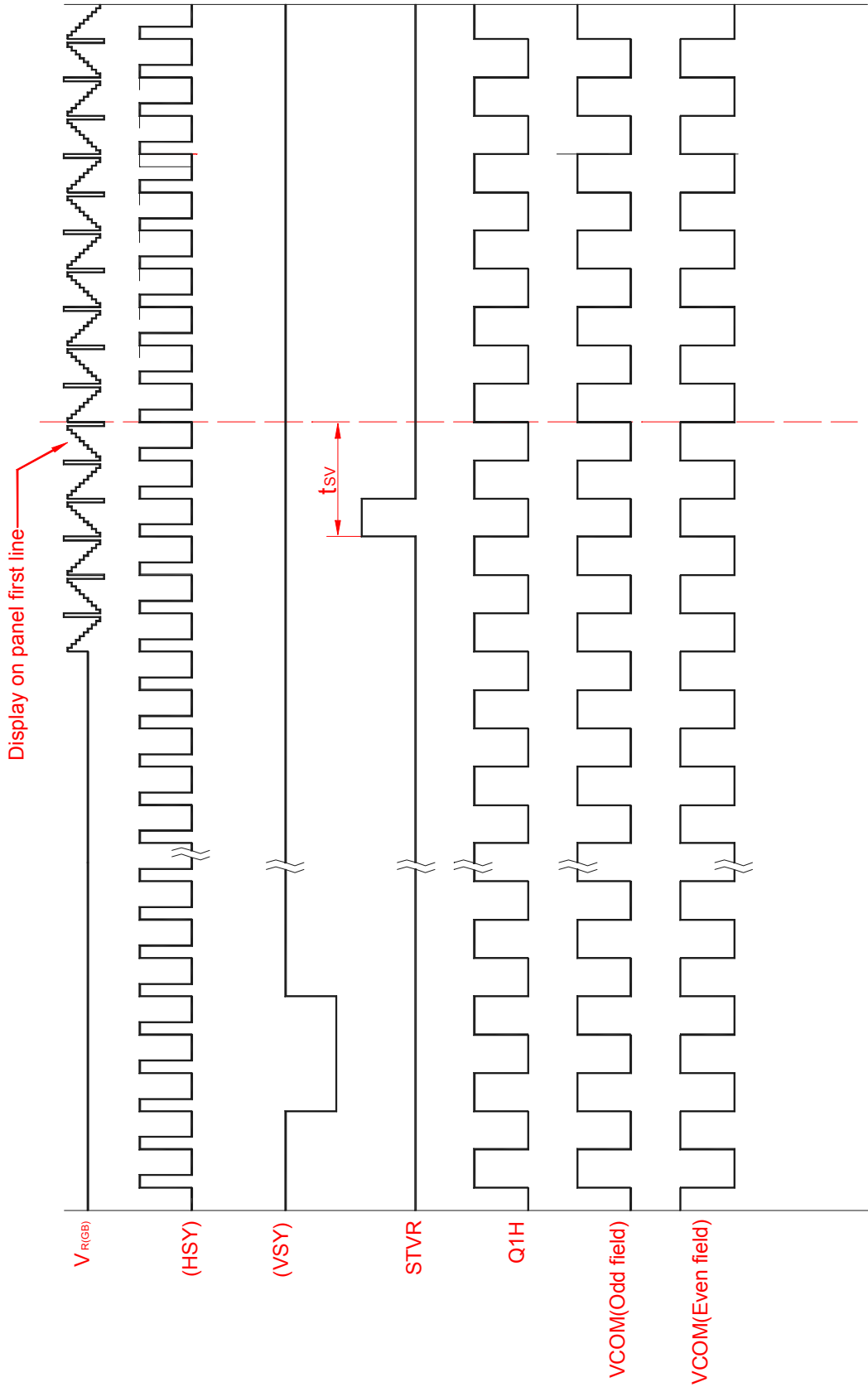

Fig.6-(b) Vertical timing (From down to up)